



Puertas & Portones Automáticos, S.A. de C.V.
¡Nuestra pasión es la Solución!....

» OPERADOR INVERTER ENCODER INCL TAB 0.75K 220V MARCA POWEVER
MOD. A2-PE200/PE200B-SF, MOD. A2-PE500/PE500B-2F.



A2-PE200/PE200B-2F
A2-PE500/PE500B-2F

MANUAL DE INSTALACION

Para Modelos A2.

Descargar en PDF



(229) 461-7028

portonesautomaticos@adsver.com.mx
portonesautomaticos@prodigy.net.mx



V02.23



(229) 927-5107, 167-8080, 167-8007, 151-7529.

www.adsver.com.mx

Contents

Introduction.....	2
Inspection.....	3
General Characteristic.....	3
Specifications.....	4
1. Specifications for Controller.....	4
2. Specifications for Motor.....	5
Operating Instructions.....	6
1. Basic Function.....	6
2. Control Key/Button.....	6
3. Install limit switch.....	6
4. Safety.....	7
Maintenance.....	7
Size.....	8
System Operation.....	10
Error Table.....	19
Port Table.....	20

Introduction

Thank you for choosing High Speed Door Servo Control System.

Please read this manual carefully before you start to use the system. In this manual you will find instructions for how to set the operating code the controller, malfunction diagnostics and debugging, and routine maintenance.

Notice:

- Before connecting the system to live wire place make sure the power supply is off.
- Please make sure the power voltage in the main circuit is the same as controller's rated voltage. Also please make sure the ground terminal is properly and reliably connect to the ground wire.
- DO NOT touch output terminal directly. DO NOT short circuit the output terminal and out shell.
- After the power supply is cut, and before the LCD is off, there still high voltage electricity in the circuit, so DO NOT touch the internal wiring and electronic components.
- Internal wiring and electronic components are very sensitivity to static electricity, so DO NOT let any object contact the internal wiring and electronic components of motor driver and the main circuit of the touch control panel.

Inspection

All product has passed inspection and testing before is leaving the factory.

When you open the unit place make sure there is no damager during shipping.

Also to confirm the equipment ratings are matching your requirement.

General Characteristic

Our servo control system is suitable for rapid door and spiral doors.

The system is in compact package, with high torque and high operating speed, lower noise, high reliability, smooth and soft operating curves, it's suitable for high speed and intensive usage environment.

The rolling curtain can be controlled by wall switch, push button, bluetooth, radar, safety edge, photo eye, induction loops, etc.

Specification

Specification for Controller

Model	PE200	PE500	
Enclosure material	SPCC		
Dimension(L*W*H)	340x195x95(125)(include E-STOP)		mm
Installation method	Vertical installation without vibration		
Power supply	1N~200-240		V
Power frequency	50/60		Hz
Rate output power	1.5		KW
External power supply	24		VDC
	0.4		A
Ambient temperature	-10 ~ +50		°C
Storage temperature	-25 ~ +55		°C
Ambient humidity	30%-85%, No condensation		
Place of use	Indoor, no direct sunlight, no dust, corrosive gas, oil mist, water vapor, etc.		
Weight(net)	3.0		Kg

Specification for Motor

Model	PE200	PE500	
Dimension(L*W*H)	440x110x180	522x130x200	mm
Rated Output Power	0.75	1.5	KW
Rated Speed	2,500	2000	RPM
Rated Torque	2.86	7.2	Nm
Power supply	1N ~ AC200-240		V
Power frequency	50/60		Hz
Power current	6.5	13	A
Ambient temperature	-10 ~ +40 ¹⁾		°C
Storage temperature	-25 ~ +55		°C
Ambient humidity	30%-85%, No condensation		
IP degree	IP54		
Limit Mode	Absolute Encoder, Proximity switch		
Self Locking Mode	Electro Mechanical Brake		
Manual Release	Handle		
Weight(net)	10.2 ²⁾	17 ³⁾	Kg

1)When using a temperature range of -20~-10°C and +40~+50°C use half of rated power output.

2)Weight includes RV50 reducer.

3)Weight includes RV63 reducer.

Operating Instructions

1. Basic Function

The system can be operated via: 1) control box; 2) jog control; 3) continuous automatic operation; 4) emergency stop; 5) single side operation box; 6) time delay; 7) radar and/or induction loops. Please refer to wiring terminal for external connections.

2. Control Key/Button

a) “↑” Key/Button: Inching control door’s opening movement or continuous automatic opening.

b) “↓” Key/Button: Inching control door’s closing movement or continuous automatic closing.

NOTE: these settings are set according to the contact; however they can be changed according to operating needs.

c) “STOP” Key/Button: Push this key under emergency situation it will shutdown the operation and the door will stop and stay at that position

d) Four keys on LCD are main menu keys.

3. Install limit switch

The limit switch of PE200 and PE500 uses the built-in absolute encoder solution, which is pre-installed in the motor before leaving the factory and does not need to be reinstalled.

4. Safety

- 1) The motor and controller **MUST** ground properly;
- 2) During the installation, commission and operation **NO ONE** is permit to stand under the door and stand in the operating path;
- 3) While installing and testing the motor package, at least half of the door's axle **MUST** be insert into the reducer.
- 4) Check if there any obstacles in the operating path, if there is please remove the obstacles before lower the gate.
- 5) **DO NOT** disassemble the controller and motor; any damagers due to this action are **NOT** cover under free warranty.

The company reserves the right to modify the product, according to improvement of technology and production process, while the basic characteristic of the product may remain some.

Maintenance

The mounting screw for the controller and motor must inspect regularly to prevent screw been getting loose and falling off. Check the internal and external wirings.

Check and change the oil for the reducer on regular basis.

Size

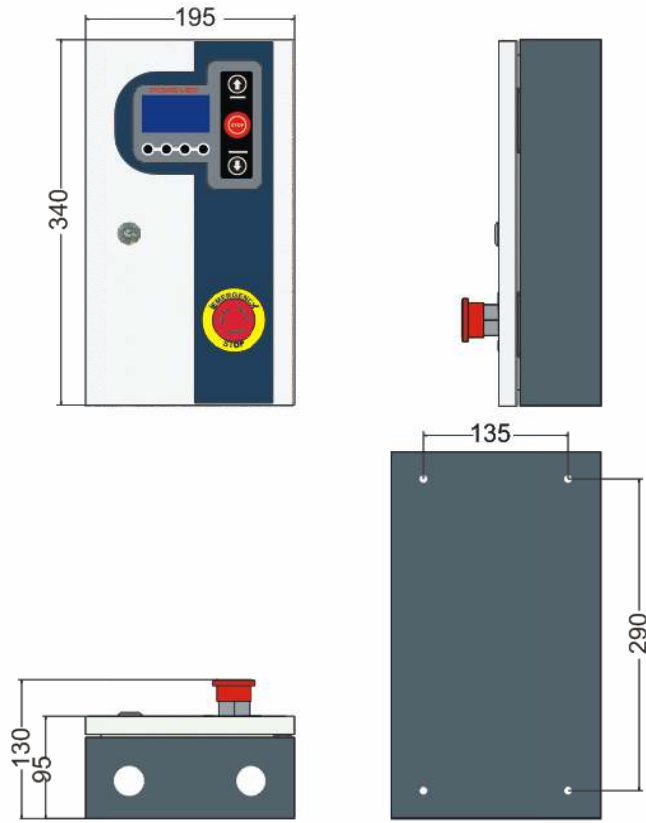

PE200/500 Controller

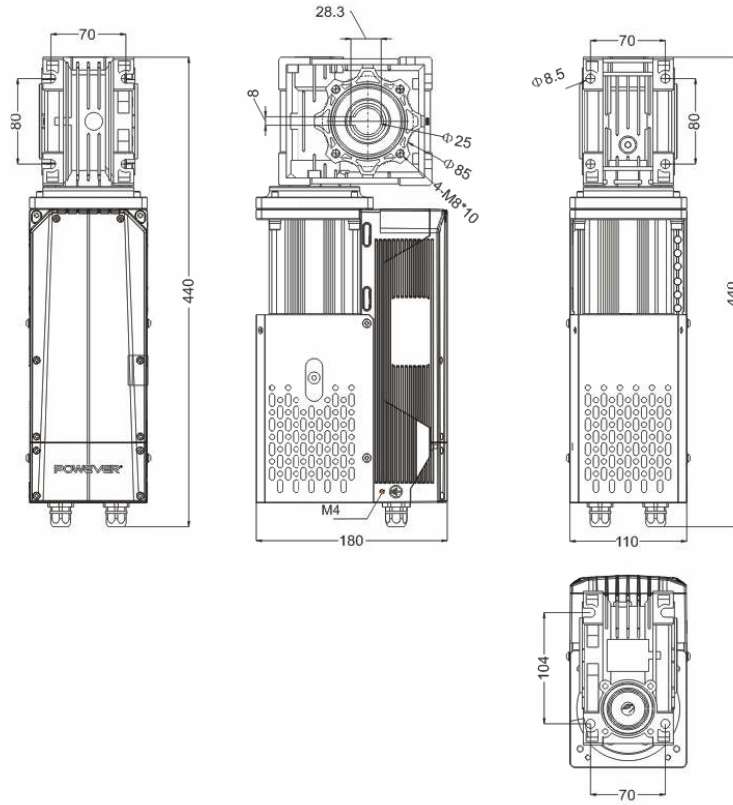

PE200(0.75KW) Motor

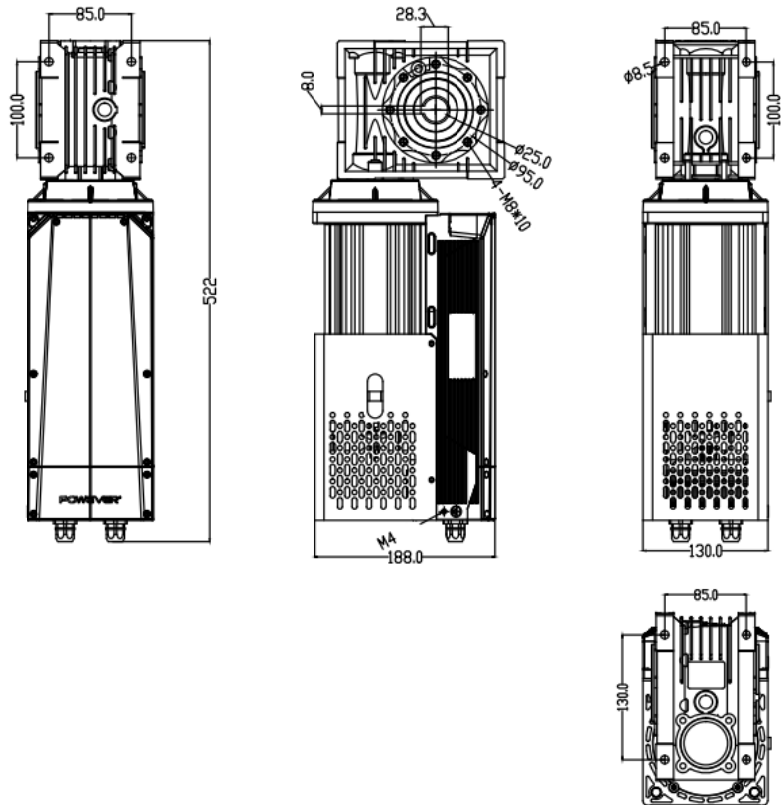

PE500(1.5KW) Motor

System Operation

MAIN-----

SERVO	(dispal)		
MODE:	(mode)		
STATUS:	(status)		
<input type="button" value="Info"/>	<input type="button" value="Err"/>	<input type="button" value="Set"/>	<input type="button" value="Mode"/>

(dispal): Torque, Speed, Position.

(mode): Manual, Auto, Jog.

(status): OK, Opening, Closing, Falut, Stop, E-stop, Safty1, Safty2, Lock, Maintenance.

Press key, input password (6668) .

Password			
6666			
<input type="button" value="+"/>	<input type="button" value="-"/>	<input type="button" value="Ok"/>	<input type="button" value="Esc"/>

Change the operation mode (Manual, Auto, Jog).

Mode Setting			
MANUAL			
<input type="button" value="Adj"/>	<input type="button" value="Save"/>	<input type="button" value="Esc"/>	

Press key, input password (default 6668).

Password			
6666			
<input type="button" value="+"/>	<input type="button" value="-"/>	<input type="button" value="Ok"/>	<input type="button" value="Esc"/>

-----1.Parameter

Index	Parameter	Value	Default
1	Opening Speed	10-125	100
2	Closing Speed	10-125	80
3	Open Slowdown dis.	30-70	50
4	Close Slowdown dis.	30-70	50
5	Auto Closing Time	<ul style="list-style-type: none"> ● Disable ● 1-120 s 	5 s
6	Output 1 Config	<ul style="list-style-type: none"> ● Non-close Limit ● Close Limit ● Non-open Limit ● Open Limit ● Opening ● Closing ● Non-limit Position ● Limit Position ● Reach Close Limit ● Failure Warning ● Disable 	Disable
7	Output 2 Config	<ul style="list-style-type: none"> ● Double Interlock Automatic Opening ● Running ● Stopped ● Auto Mode State ● E-Stop State ● Auto Closing Countdown ● Delayed Opening Countdown ● Partial Open Limit ● All Open Limit ● Safety 1 Output ● Safety 2 Output 	Disable
8	Safety 1 Height	Set the current position of the door to the failure height of safety signal 1	
9	Safety 2 Height	Set the current position of the door to the failure height of safety signal 2	
10	Partial Opening	10-100%	100
11	Display Config	<ul style="list-style-type: none"> ● Position ● Speed ● Torque 	Torque
12	Backlight Setting	<ul style="list-style-type: none"> ● 3 minute auto Off 	3 minute auto Off

		<ul style="list-style-type: none"> • 60 minute power saving • 60 minute auto off • Always On 	
13	Winter Autorun	<ul style="list-style-type: none"> • Off • 1-999 min 	Off
14	Wireless Remote	<ul style="list-style-type: none"> • Off • On 	Off
15	RS485 Interlock	<ul style="list-style-type: none"> • Off • On 	Off

-----2.Limit Switch Setting

Select the limit switch type:

Option	Remaks
Absolute Encoder	
Proximity Switch	

Limit Switch
Proximity Switch

Limit Switch
Absolute Encoder

Ensure the open direction.

Press OPEN-key
Direction
Correct?

Choose door type:
Rapid door or Spiral door.

Door Type
Rapid door

If limit switch is Proximity Switch,
we shall find the Origin Position first.

Origin Position
Lift the door

Ensure the open direction.

Press OPEN-key
Direction
Correct?

Next, we shall set the Open and Close Limit.

Open Limit

Ok
Ecs

Close Limit

Ok
Ecs

Finally, we will see the result.

Calibrate
Programmed

Ecs

or

Calibrate
Failure

Ecs

-----3.RTC Config

Configure the date and time of the real time clock.

1. Year
2. Month
3. Day

↑
↓
Ok
Esc

Year
2015

+
-
Save
Esc

Index	Parameter
1	Year
2	Month
3	Day
4	Hour
5	Minute

-----4.Advanced Setting

-----1.Communication

Set RS485 slave address and baudrate.

1. Slave Address
2. Baud Rate

↑ ↓ Ok Esc

Slave Address
1

+ - Save Esc

Baud Rate
4800

Adj Save Esc

-----2.Contact Type

Set the contact type.

Index	Parameter	Value	Default
1	Ext E-Stop	N.O / N.C	N.C
2	Safety1	N.O / N.C	N.O
3	Safety2	N.O / N.C	N.O
4	Auto Open	N.O / N.C	N.O
5	Partial Open	N.O / N.C	N.O
6	Start	N.O / N.C	N.O
7	Open Limit	N.O / N.C	N.O
8	Close Limit	N.O / N.C	N.O
9	Lock Input	N.O / N.C	N.O

1. Ext E-Stop
2. Safety1
3. Safety2

↑ ↓ Ok Esc

Ext E-Stop
N.O

Adj Save Esc

-----3.Adv Parameter

First, input password (7779).

Password
7777

+ - Ok Esc

Select the parameter index.

Adv Parameter
Index: 01

+ - Ok Esc

Change the parameter value.

Adv Parameter
P01: 0001

+ - Save Esc

-----4. Maintenance

Set the work cycles before the next maintenance.

Maintenance
0 Thousand

+ - Save Esc

-----5. System Config

Input password (default 1111).

Password
0000

← → Ok Esc

1. Cycle
2. Time
3. Password

↑ ↓ Ok Esc

Set the work cycles and time.

Work Cycle
0 Thousand

+ - Save Esc

Work Time
0 Days

+ - Save Esc

Change the system config password.

Password

1111

-----6.Auto Test

Run the system auto testing.

Auto Test

(display)

0

-----5.Language

Set the system language.

Language

English

-----6.Default

Restore factory settings.

Default ?

Info

-----1.Input Query

Displays the input states.

Index	Port	State
1	Manual Open	0: No Signal 1: Has Signal
2	Manual Close	
3	Manual Stop	
4	Ext E-Stop	
5	Safety 1	
6	Safety 2	
7	Auto Open	
8	Partial Open	
9	Start	
10	Open Limit	
11	Close Limit	
12	Lock Input	
13	Remote Close	
14	Remote Open	
15	Remote Stop	

1. Manual Open	0	
2. Manual Close	0	
3. Manual Stop	0	
<input type="button" value="↑"/>	<input type="button" value="↓"/>	<input type="button" value="Esc"/>

-----2.Sum Counter

Displays the work cycles.

Sum Counter
88
<input type="button" value="Esc"/>

-----3.Maint Counter

Displays the work cycles after maintenance.

Maint Counter
88
<input type="button" value="Esc"/>

-----4.Fault Memory

Displays the error history.

01. ERR23	No	
Limit Settings		
2015-11-17 10:25		
↑	↓	Esc

-----5.System Query

Displays the value of selected system register.

System Query 1		
0		
↑	↓	Esc

-----6.Version

Displays the system version.

-----7.RTC Query

Displays the current date and time of the real time clock.

RTC Query		
2015-11-17		
12:12:12		
		Esc

-----Err

Shows the current error message.

ERR 19		
Absolute Encoder		
Failure		
		Esc

Error Table:

Error Code	Content
ERR01	Over current
ERR03	Under Voltage
ERR04	Over Voltage
ERR05	Over Voltage
ERR06	Locked Rotor
ERR07	Out Of Limit Position
ERR08	EEPROM Failure
ERR09	Over Speed
ERR10	Motor Reversion
ERR11	Overload
ERR12	Sample Current Failure
ERR13	Motor Encoder Failure
ERR14	Initial Rotor Angle Failure
ERR15	Communication Failure
ERR18	Brake Circuit Failure
ERR19	Absolute Encoder Failure
ERR20	Run Time Exceeded
ERR21	Safety 1 Exceeded During Cycle
ERR22	Safety 2 Exceeded During Cycle
ERR23	No Limit Settings
ERR24	DC24V Failure
ERR26	Mechanical Limit Failure
ERR27	Overheated
ERR28	Electromagnetic Brake Fault
ERR29	Absolute Encoder Reset
ERR30	Motor Parameter Matching Fault
ERR31	Motor Encoder Failure 2
ERR32	Motor Encoder Failure 3
ERR33	Absolute Encoder Failure 2
ERR34	Absolute Encoder Reset 2
ERR35	Absolute Encoder Run Reset
ERR36	Limit Distance Too Short
ERR38	Electromagnetic Brake Fault 2
ERR39	Motor Encoder Failure 4
ERR40	Motor Encoder Failure 5
ERR41	Absolute Encoder Position Unstable
ERR42	Motor Dir Err In Limit Setting
ERR43	Proximity Switch Too Close
ERR44	Limit Distance Too Long
ERR45	Absolute Encoder Dir Failure

ERR47	Limit HALL Value Not Match
ERR48	Abnormal Door Position
ERR49	Limit Abnormal
ERR50	Motor Too Heart
ERR51	Drive Too Heart
ERR53	Electromagnetic Brake Error 3
ERR54	System Matching Fault
ERR55	IPM Too Heart
ERR56	Out Of Door Track

Port Table:

Port Table Of Motor:

Port	Function	Remark
L1	L1	AC220V input, connect to controller.
N1	N1	
PE	PE	
B1	Motor signal input	connect to controller
B2		
B3		
S1		

Port Table Of Controller:

Port	Function	Remark
L	L	1N~AC220V input
N	N	
PE	PE	
L1	L1	1N~AC220V output , connect to motor
N1	N1	
PE	PE	
B1	Motor signal output	Connect to motor
B2		
B3		
S1		
8	COM/GND	
9	Manual open input	NO
10	Manual close input	NO
11	Manual stop input	NO
12	COM/GND	
13	DC+24V	
14	COM/GND	
15	Safety input 1*	NO(Safety edge, photocell, etc) , stop
16	Safety input 2*	NO(Safety edge, photocell, etc), reverse to open limit when closing
17	Automatic open input*	NO(Radar, sensor, etc)
18	Partial open input*	NO(Radar, sensor, etc)
19	COM/GND	
20	Start input*	NO
21	Open limit switch input*	NO
22	Close limit switch input*	NO
23	Interlock input*	NO
24	DC+24V	
25	COM/GND	
26	Output 1A	NO, refer to "Output 1 config"
27	Output 1B	
28	Output 2A	NO, refer to "Output 2 config"
29	Output 2B	
30	RS485+	
31	RS485-	
32	Emergency stop input*	NC
33	COM	
34	Open button input	34 and 35 short connected. If you need to provide a open button for other equipment to use, disconnect the short circuit, 35 and 36 connect to other equipment
35	Open button output	
36	COM	
37	Close button output	37 and 38 short connected. If you need to provide a close button for other equipment to use, disconnect the short circuit, 37 and 36 connect to other equipment
38	Close button input	



Puertas & Portones Automáticos, S.A. de C.V.
¡Nuestra pasión es la Solución!....

»OPERADOR INVERTER ENCODER INCL TAB 0.75K 220V MARCA POWEVER
MOD. A2-PE200/PE200B-2F, MOD. A2-PE500/PE500B-2F.



Puertas & Portones Automaticos S.A. de C.V.
¡Nuestra pasión es la Solución!....

(229) 461-7028

portonesautomaticos@adsver.com.mx
portonesautomaticos@prodigy.net.mx



V02.23

(229) 927-5107, 167-8080, 167-8007, 151-7529.



www.adsver.com.mx